

Full Featured Keyless Entry System

with Optional Starter Defeat and Passive Immobilize Feature

SYSTEM MANUAL

STANDARD FEATURES

Some of the system's standard features include:

- Two 4-button remote transmitters
- Remote keyless entry
- LED Status indicator
- Valet switch

OPTIONAL FEATURES

This system has many optional features that may not be compatible with some vehicles, and may require additional parts and/or labor. Please contact your dealer for more details.

- Flashing Parking Lights
- Starter Defeat
- Illuminated Entry
- Trunk/hatch Release
- Passive Immobilize feature
- Horn Honk output
- Remote Panic feature

REMOTE TRANSMITTER LAYOUT

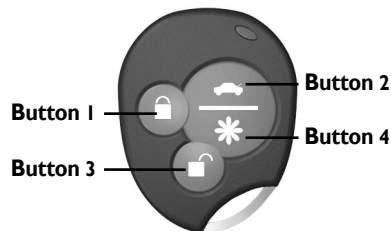

NOTE: Transmitter cosmetics may differ, but button functions remain the same.

SYSTEM OPERATION

REMOTE LOCKING

To lock the doors press button 1:

- The horn will beep once.*
- The parking lights will flash once.*
- The doors will lock.
- The LED will turn solid for 10 seconds then start flashing slowly.
- The optional starter defeat will engage.*

* Optional Feature.

The optional Starter Defeat feature disables the vehicle's starter until button 2 is pressed, or until the Emergency Override is performed.

If the optional Ignition Trigger feature is programmed, turning on the ignition before pressing button 2 to unlock the doors will cause the horn to honk and the lights to flash for 30 seconds. Press button 2 to disarm the ignition trigger and allow the vehicle to start.

REMOTE UNLOCKING

To unlock the doors press button 2.

- The horn will beep twice.*
- The parking lights will flash twice.*
- The doors will unlock.
- The dome light will turn on.*

* Optional Feature.

NOTE: If the optional two-step unlock feature is installed, pressing button 2 will unlock only the driver's door. Press button 2 again to unlock all remaining doors.

PASSIVE STARTER DEFEAT

If the optional starter defeat is installed, the system can be programmed to automatically disable the starter 45 seconds after turning off the ignition as an extra measure of security in the event the vehicle is accidentally left unlocked. During the 45 second countdown, the LED will flash rapidly to indicate the passive starter defeat sequence has begun. After 45 seconds, the LED will flash slowly and the vehicle's starter will be disabled.

IGNITION TRIGGER

After the system is remotely locked, turning on the ignition before remotely unlocking the system activates the optional ignition trigger feature (if selected during installation). The horn will honk and the parking lights will flash for 30 seconds. To deactivate the feature once triggered, press button 2 on the transmitter or use the override procedure (see below).

HORN OUTPUT

If the optional Horn Honk feature is connected, the horn will provide confirmation chirps when locking or unlocking the doors, or when the Panic feature is activated.

REMOTE PANIC

If the optional horn honk output is installed, pressing button 4 for three seconds will trigger the Panic mode. The horn will honk and parking lights will flash for 30 seconds, or until button 4 is pressed again.

EMERGENCY OVERRIDE

If the optional starter defeat is installed and your remote is lost or fails to operate, you can manually override the starter defeat.

Turn on the ignition, then press the override/valet switch for two seconds. The starter defeat will disengage and the system will enter valet mode.

VALET MODE

When the system is placed into valet mode, the optional starter defeat, ignition trigger, and passive starter defeat will be disabled. To put your system into valet mode, turn the ignition on and hold the override/valet switch for 3 seconds. The horn will chirp once (if installed) and the LED will turn on solid to confirm valet mode. To exit valet mode, repeat the same procedure. The horn will chirp twice and the LED will turn off to confirm valet mode exit.

AUXILIARY OUTPUT

The auxiliary output may be used to activate an optional feature such as trunk release. Press and hold button 3 for three seconds to activate.

ILLUMINATED ENTRY

The optional Illuminated Entry turns on the dome light when the doors are remotely unlocked. The dome light will remain on for 30 seconds or until the ignition is turned on.

LED STATUS MODES

Locked = Slow flash

Disarmed = Off

Passive Starter Defeat Warn = Rapid flash

Valet Mode = Solid

INSTALLATION INSTRUCTIONS

Before you begin the installation:

- This product must be installed by qualified personnel according to these instructions.
- Verify with the customer the desired location for the program switch and LED.
- Always use a multimeter when verifying vehicle wiring.

Installation Notes:

- Do not install the main unit in the engine compartment.
- Make all wiring connections to the vehicle before connecting the main 15-pin connector harness to the main unit.
- Mount the main unit in a secure area, away from vehicle computers and heating/air conditioning ducts. Mount the unit as far away from metal objects as possible to increase the range of the remote transmitters.
- When running the harness wires through the vehicle, be careful to run them where they cannot be damaged or shorted. Keep them away from any moving parts or areas of high heat. Use rubber or plastic grommets to protect the harness wires where they pass through holes in metal panels.

Main Harness:

- **BLACK WIRE** - Ground input (-). Connect to a solid chassis ground that is clean and free of paint or dirt.
- **RED WIRE** - +12V battery input.
- **WHITE WIRE** - Parking light output (+). Connect to the wire that shows +12V when the parking lights are on. If the vehicle's parking light circuit exceeds 10A, a relay is

required. For vehicle's with independent left and right parking light circuits, the parking light wires must be connected using diodes to keep the circuits separate.

- **WIRE - Unlock #87** normally open input 10A fuse. (see *Door Lock Wiring Diagrams*)
- **BLUE/BLACK WIRE** - Unlock #30 common output. (see *Door Lock Wiring Diagrams*)
- **BROWN/BLACK WIRE** - Unlock #87A normally closed input. (see *Door Lock Wiring Diagrams*)
- **VIOLET/BLACK WIRE** - Lock #87 normally open input 10A fuse. (see *Door Lock Wiring Diagrams*)
- **GREEN/BLACK WIRE** - Lock #30 common output. (see *Door Lock Wiring Diagrams*)
- **WHITE/BLACK WIRE** - Lock #87A normally closed input. (see *Door Lock Wiring Diagrams*)
- **ORANGE WIRE** - Armed Output (-) 500mA. The ORANGE wire provides ground when the unit is armed to activate a starter disable relay. Connect to a relay for starter defeat.. (See *Relay Wiring Diagrams*)
- **BLACK/YELLOW** - Dome light output (-) 500mA. Connect to a relay to activate the dome light when the system is unlocked. (See *Relay Wiring Diagrams*)
- **GRAY WIRE** - Auxiliary output (-) 500mA. Connect to a relay for optional trunk release etc. (See *Relay Wiring Diagrams*)
- **BROWN WIRE** - Horn honk output (-) 500mA. Connect to a relay to honk the vehicle's horn. (See *Relay Wiring Diagrams*)

- **BLUE/WHITE WIRE** - Passenger unlock output (-) 500mA. The BLUE/WHITE wire provides a ground to unlock the passenger doors when the unlock button on the transmitter is pressed two times. To install the two-step unlock feature, the BLUE/BLACK and BROWN/BLACK wires must be run directly to the driver's door actuator unlock wire and the BLUE/WHITE wire must be connected to a relay to unlock the passenger doors. (see *Optional Two-Step Unlock Diagrams*)

- **YELLOW WIRE** - Ignition input (+). Connect to the main ignition wire that switches +12V and does not drop out during cranking.

2-Pin Red Connector: Plug-in connector port for LED. Mount LED in an area where it may be easily seen from either side of the vehicle.

2-Pin Blue Connector: Plug-in connector port for program/service switch. Mount program switch in an area that is easily accessible from the driver's position.

PROGRAMMABLE FEATURES

To enter program mode:

1. Turn on ignition.
2. Within 5 seconds, press valet switch 5 times.
 - The horn will provide a long chirp, to indicate entering program mode.

3. Press the valet switch the number times equal to the desired feature.
 - The horn will chirp and lights/LED will flash, each time the valet switch is pressed.
4. Within 5 seconds, press the transmitter button corresponding to the desired operating mode for that feature.
 - The horn will chirp and lights will flash to indicate the setting.
 One chirp/flash = Button 1
 Two chirps/flashes = Button 2
5. Turn off ignition to save changes.

FEATURE DESCRIPTION

1. Ignition Lock/Unlock. Automatically locks the doors when the ignition is turned on and unlocks when the ignition is turned off.
2. Door Unlock Pulse. Selects between a single or double unlock pulse.
3. Chirp Mode. Selects or bypasses the system's lock/unlock confirmation chirps.
4. Door Lock PulseLength. Selects between a .75-second or 3-second lock/unlock pulse.
5. Passive Starter Defeat. Enables the starter defeat to automatically activate 45 seconds after turning off the ignition.
6. Ignition Trigger. Enables the ignition trigger feature when the system is remotely locked.

Remote Programmable Features:

Step	Function	Button 1 (Default)	Button 2
1.	Ignition Controlled Door Locks	On	Off
2.	Door Unlock Pulse	Single	Double
3.	Chirp Mode	Standard	Silent
4.	Door Lock Pulse Length	.75 Seconds	3 Seconds
5.	Passive Starter Defeat Enable	Off	On
6.	Ignition Trigger Feature	Off	On

DEFAULT RESET

To reset all programmable features to their factory default settings:

1. Turn on ignition.
2. Within 5 seconds, press valet switch 5 times.
 - The horn will provide a long chirp, to indicate entering program mode.
3. Press transmitter button 3. The LED will flash 3 times, pause then continue flashing. All programmable features will be reset to the default position.

ADDING / DELETING REMOTE TRANSMITTERS

Adding new transmitters to the system will automatically delete all other remotes that were previously operating the system.

NOTE: You must code all desired remotes at this time. The unit can learn a maximum of three transmitters.

To enter Code Learning Mode:

1. Turn ignition key on, off, on, off, on and leave on within 5 seconds. The horn will chirp (if installed) and the LED / parking lights will flash once.
2. Press and hold valet switch for 3 seconds. The horn will chirp and the LED / parking lights will flash 3 times.
3. Release the program switch.
4. Program all desired remotes by pressing button 1 on each of the transmitters. The parking lights will flash after the system has learned each remote control.
5. Turn ignition key off. Remotes are now programmed to the system.

DOOR LOCK WIRING DIAGRAMS

NEGATIVE PULSE DOOR LOCK SYSTEM

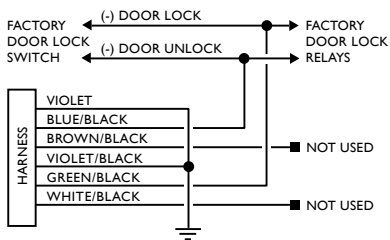

POSITIVE PULSE DOOR LOCK SYSTEM

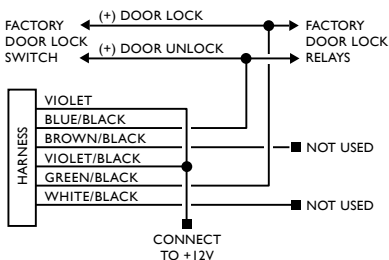

ADDING ACTUATORS

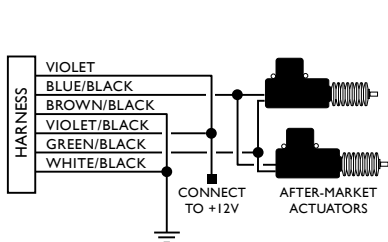

VACUUM DOOR LOCK SYSTEM

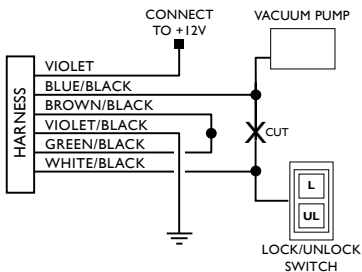

REVERSE POLARITY DOOR LOCK SYSTEM

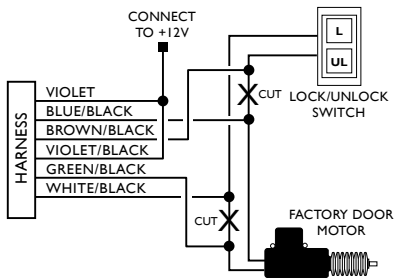

OPTIONAL TWO-STEP UNLOCK WIRING DIAGRAMS

TWO-STEP UNLOCK NEGATIVE PULSE

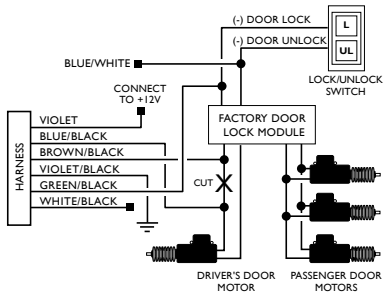

TWO-STEP UNLOCK POSITIVE PULSE

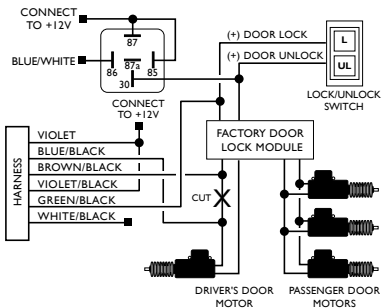

TWO-STEP UNLOCK REVERSE POLARITY

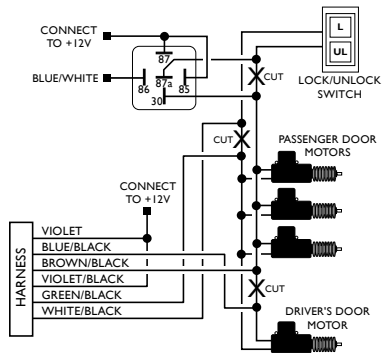

TWO-STEP UNLOCK ADDING ACTUATORS

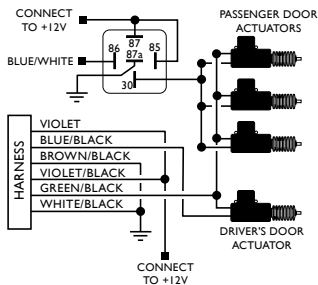

KEYLESS ENTRY WIRING DIAGRAM

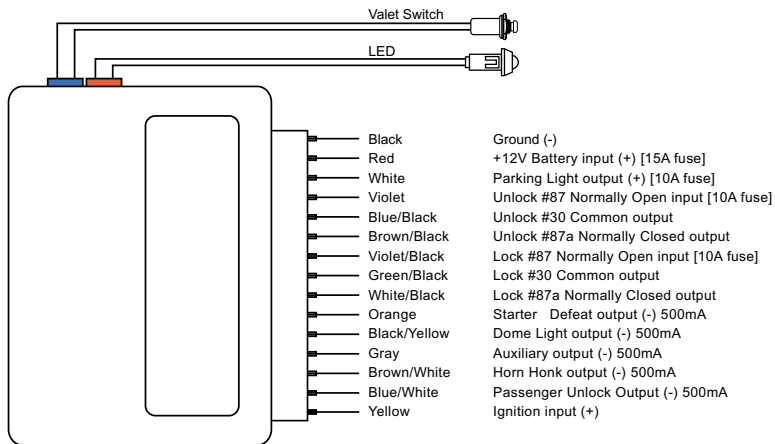

RELAY WIRING DIAGRAMS

STARTER DEFEAT

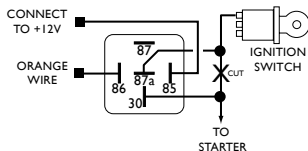

TRUNK RELEASE DIAGRAM

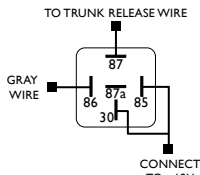

HORN HONK / DOME LIGHT DIAGRAMS

