

Passive Vehicle Immobilizer System

Owner / Installation Manual

Standard Features

The system has the following standard features:

- (2) 1-button remote controls
- Two Built-in relays for starter and/or fuel system disable
- LED indicator
- Valet switch
- Passive or active arming
- Ignition trigger

Optional Features

The system has many optional features that may require additional parts and/or labor.

- Remote keyless entry (Door lock/unlock)
- Optional third circuit defeat output
- Illuminated entry
- Horn honk
- Anti-carjacking
- Selectable parking light/horn output

Adding or Deleting Remote Controls

Follow the steps below to code a replacement transmitter into the system (maximum of 4). If there are less than 4 transmitters, code the last transmitter multiple times to fill all 4 transmitter slots and force any lost or stolen transmitters out of the system.

To enter Code Learning Mode:

1. Turn ignition key on, off, on, off, and leave on within 5 seconds.
 - The LED will will flash 3 times.
2. Press and hold the valet switch for 2 seconds.
 - The LED will will flash 5 times.
3. Release the valet switch.
4. Program all desired remotes by pressing the button on each of the transmitters.
 - The LED will will flash after the system has learned each transmitter.
5. Turn off the ignition.

Wiring Diagram

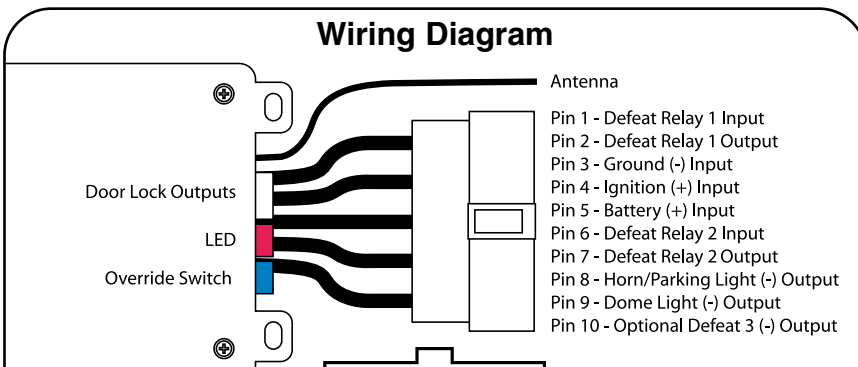

- Pin 1 - Defeat Relay 1 Input. Locate the vehicle starter and verify correct operation of the circuit using a multimeter. Cut this wire then verify that the vehicle does not crank. Connect the key side of the wire to Pin 1. Connect the opposite wire to Pin 2.
- Pin 2 - Defeat Relay 1 Output. See *Pin 1 description*.
- Pin 3 - Ground input (-). Connect to a solid chassis ground that is clean and free of paint or dirt.
- Pin 4 - Ignition input (+). Connect to the main ignition wire that switches +12V and does not drop out during cranking.
- Pin 5 - +12V Battery Input. Connect the red fused wire on the main harness to a constant +12V source.
- Pin 6 - Defeat Relay 2 Input. Defeat Relay 2 can be used for an additional circuit defeat such as a fuel pump relay. This allows multiple points of protection.
- Pin 7 - Defeat Relay 2 Output. See *Pin 6 description*.
- Pin 8 - Horn Honk output (-). Connect to a relay to honk the vehicle's horn or flash the parking lights for Arm, Disarm, and Anti-Carjacking indications.
- Pin 9 - Dome Light output (-). Connect to a relay for dome light activation. This wire may also be programmed as a Factory Alarm Disarm Output.
- Pin 10 - Optional Defeat 3 Output (-). Connect to a relay for optional circuit defeat. When the unit activates the circuit disable relays, this wire provides a ground output to activate a 3rd circuit defeat such as ignition.

Plug in Connectors:

- 3-Pin White Connector:** Plug-in connector port for door lock harness or optional door lock relay module (PDLM-3).
- BLUE WIRE - negative unlock output (-).
 - RED WIRE - +12V low current output (+) for relay modules, or inverters. 100mA relay trigger only. Do NOT use as a power source for door lock relays.
 - GREEN WIRE - negative lock output (-).

2-Pin Blue Connector: Plug-in connector port for Valet switch. Mount the switch in an area that is easily accessible from the driver's position.

System Operation

ARMING OPERATION

To arm the system manually, press the transmitter button.

- The horn will chirp once.*
- The doors will lock.*
- The starter and other selected circuits will be disabled.
- The LED will start flashing slowly, indicating the system is armed.

* If Installed

If the ignition is turned on while the system is armed, the Ignition Trigger will begin honking the horn for 30 seconds. Press the transmitter button or use the Emergency Override procedure to disarm the system.

PASSIVE ARMING

The Passive Arming feature allows the system to arm automatically after turning off the ignition.

To arm the system passively turn off the ignition:

1. After 5 seconds:
 - The LED will start flashing quickly to indicate the system is about to arm.
2. After 10 seconds:
 - The horn will chirp once.
 - The doors will lock.
 - The LED will flash slowly to indicate that the system is armed. The system can also be armed at any time by pressing the transmitter button.

NOTE: The system may be armed at any time by pressing the transmitter button. If the Auto Transmit Mode is enabled, the Passive Arming feature will be delayed until the transmitter is out of range.

DISARMING OPERATION

- The optional illuminated entry feature will turn on the dome light for 30 seconds (if programmed for Factory Alarm Disarm, the system will pulse the factory disarm wire).*

* If Installed

AUTO TRANSMIT MODE

The Auto Transmit mode allows complete hands-free operation of the system. The Passive Arming feature automatically arms the system after the remote transmitter is out of range of the vehicle.

To enable or disable Auto Transmit mode press the transmitter button and hold for 5 seconds.

- The LED will flash once to indicate Auto Transmit mode is on.
- The LED will flash twice to indicate Auto Transmit mode is off.

During normal operation, every time the transmitter button is pressed, the LED will blink to indicate the current status of the Auto Transmit Mode.

Passive Arming with Auto Transmit:

1. Make sure the remote is set for Auto Transmit.
2. Walk away from the vehicle. The system will not passively arm if the transmitter is within range of the vehicle and set for Auto Transmit.
 - The Passive Arming feature will automatically arm the system once the transmitter is out of range of the vehicle.

To disarm the system if armed passively:

1. Walk up to the vehicle.
2. Once the transmitter is within range of the vehicle:
 - The horn will chirp twice.
 - The doors will unlock.
 - The LED will stop flashing and the system will disarm. The system can also be disarmed by pressing the transmitter button.

NOTE: If the system was armed manually, it must also be disarmed manually. This allows the Auto

HORN CHIRPS

For audible confirmation of the ARM and DISARM functions, the horn can be programmed to chirp. *This feature requires the optional horn output to be connected, and programmed during installation.*

IGNITION LOCK

The ignition locking feature allows the doors to automatically lock and unlock when the ignition key is turned on and off. *This feature may be disabled during installation.*

VALET MODE

When the system is placed into the Valet Mode, the system can still be armed, but the Passive Arming / Auto Transmit functions will be disabled.

To enter or exit Valet Mode:

1. Turn the ignition key on.
2. Press and hold the valet switch for 5 seconds.
 - The LED will turn on solid indicating the system is in Valet Mode.
 - The LED will turn off and exit Valet Mode.

EMERGENCY OVERRIDE

If the transmitter becomes lost or fails to operate, the system can be disarmed by using the emergency override feature.

To override the system:

1. Enter the vehicle.
2. Turn on the ignition key.
3. Press the Valet switch for 10 seconds.
 - The disabled circuits will be re-enabled and the vehicle can be driven.

ANTI-CARJACKING FEATURE

With the Anti-Carjacking feature enabled and the ignition on, if the transmitter is moved out of range of the vehicle for more than 90 seconds, the horn will begin chirping for 15 seconds indicating the anti-carjacking feature has been triggered. If the transmitter is not moved back within range, the horn will continue to sound for 5 minutes, and the circuit

Remote Programmable Features:

Step	Function	On (Default)	Off
1.	Ignition Lock	On	Off
2.	Passive Unlock	On	Off
3.	Normal/Silent Arming	Silent	Normal
4.	Door Unlock Pulse	Single	Double
5.	Door Lock Pulse Length	.75 Seconds	3 Seconds
6.	Wire #9 Output on Disarm	Dome Light Output	Factory Alarm Disarm
7.	Anti-Carjack Feature	Enabled	Disabled

Remote Programmable Features

To change programmable feature:

1. Turn off the Auto Transmit mode.*
2. Turn on the ignition.
3. Wait 2 seconds.
4. Within 10 seconds press valet switch 5 times.
 - The LED flashes 3 times indicating the system is now in program mode.
5. Press valet switch the number of times that equal to the feature you wish to change. (Example: to turn feature #3 off press the valet switch 3 times).
 - The LED will flash each time the switch is pushed.
6. Press the transmitter button to reverse the current setting.
7. Turn off the ignition.

* If the Auto Transmit mode is left on, the programmable features may be reset to the default settings or undesired operation may result.

NOTE: You must re-enter program mode for each feature you wish to change.

Programmable Features

Program #1: Ignition Lock
 On = Ignition auto lock
 Off = No ignition auto lock

Program #3: Normal/Silent Arming

On = Silent operation
 Off = Normal operation

Program #4: Door Unlock Pulse

On = Single
 Off = Double

Program #5: Door Lock Pulse Length

On = 0.7 second door lock/unlock pulse
 Off = 3 second door lock/unlock pulse

Program #6: Wire #9 Output on Disarm

On = Dome Light Output for 30 seconds
 Off = Factory Alarm Disarm Output

Program #7: Anti-Carjack Feature

On = Anti-Carjacking Enabled
 Off = Anti-Carjacking Disabled

Default Reset

To reset all programmable features to the factory default settings:

1. Turn on the ignition.
2. Wait 2 seconds.
3. Within 10 seconds press valet switch 5 times.
 - The LED flashes four times indicating the system is now in program mode.
4. Press the transmitter button once. The LED will flash 4 times and all programmable features will be reset to the **On** position.